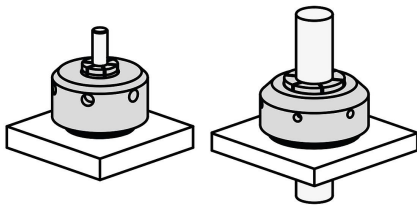

Item description/product images

**Description****Material:**

Clamp nut aluminium.
Collet steel.

Version:

Clamp nut hard anodised.

Note:

The contour of the workpiece to be clamped is machined into the collet.

The collet must be pre-tensioned at a setting of 15° before the workpiece contour is machined in.

By using the engraved degree numbers, the same tightening torque can always be achieved for secure clamping of the workpiece, even without a torque wrench.

The radial clamping travel of the collet 03166-10-01910 is 0.025 mm per 15° rotation. The recommended clamping travel is 0.07 mm. The maximum permissible clamping travel is 0.38 mm.

The radial clamping travel of the collet 03166-10-04950 is 0.05 mm per 15° rotation. The recommended clamping travel is 0.1 mm. The maximum permissible clamping travel is 0.64 mm.

The positioning collar enables a precise seat.

Workpiece repeat accuracy: ± 0.02 mm.

Type of operation:

The clamp nut is tightened using a hook wrench.

Technical data:

See Downloads, Technical Information.

Supplied with:

Form A: Machinable collet consisting of clamp nut and collet.

Form B: Collet.

Including cap screws for fastening the collet. (metric and inch)

Drawing reference:

1) cap screw

Drawings

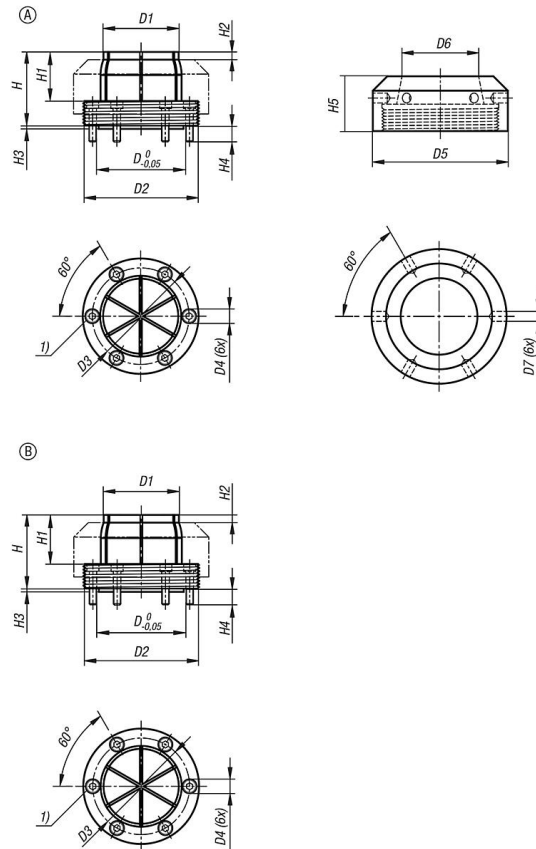

Overview of items

Order No.	Item	Form	D	D1	D2	D3	D4	D5	D6	D7	H	H1	H2	H3	H4	H5	Tightening torque max. Nm	Clamping range min. - max.	Clamping force kN
03166-10-01910	Machinable Collet System	A	23,9	19,1	38,1	29	M3x16	50,8	20,1	6,4	35,6	22,9	4,6	2,5	6,8	25,4	81,5	2,5 - 15,9	17,3
03166-10-04950	Machinable Collet System	A	55,9	49,5	76,2	63,8	M5x22	88,9	50,5	6,4	48,3	32,4	5,1	2,5	11,1	36,2	135,5	5,1 - 45,7	17,8
03166-10-01911	Collet	B	23,9	19,1	38,1	29	M3x16	-	-	-	35,6	22,9	4,6	2,5	6,8	-	-	2,5 - 15,9	-
03166-10-04951	Collet	B	55,9	49,5	76,2	63,8	M5x22	-	-	-	48,3	32,4	5,1	2,5	11,1	-	-	5,1 - 45,7	-